

Feed E7C 1838

MT Parts: 0407 059 610
11 Halsey Circuit, Roseworthy S.A. 5331
171 Dugan Street, Kalgoorlie W.A. 6430
parts@mtunderground.com
www.mtunderground.com

COP 1838MUX FRONT HEAD PARTS

ITEM	PART NUMBER	DESCRIPTION	QTY
1	MT3115 3236 00	WIPER	2
2	MT3115 3196 02	GUIDE	2
3	MT3115 2386 00	CUP SEAL	3
4	MT3115 3197 02	GUIDE	2
5	MT0663 2104 94	O-RING	2
6	MT9754 0067 80	FLUSHING KIT (incl. items 1-5)	0
7	MT3115 2232 00	DRILL COLLAR ST45	1
7.1	MT3115 2231 00	DRILL COLLAR ST38	1
8	MT3115 3195 01	COVER	2
9	MT3115 3061 00	DOWEL PIN	1
10	MT3115 3062 00	WASHER	1
11	MT3115 3063 00	BUSHING	1
12	MT3115 3190 00	FLUSHING HEAD	1
13	MT0347 6200 21	HOSE CLAMP	1
14	MT3115 3528 00	SEAL RETAINER	1
15	MT3115 2223 02	GUIDE	1
16	MT3115 3484 00	FRONT BUSH	1
17	MT0335 2177 00	CIRCLIP	1
18	MT3115 3165 00	PISTON	1
19	MT3115 3032 00SK	EXTRACTOR SEAL KIT	1

MT9754 0067 80 FLUSHING KIT 1838 MUX

ITEM	PART NUMBER	DESCRIPTION	QTY
1a	MT3115 2386 00	CUP SEAL	3
2a	MT0663 2104 94	O-RING	2
3a	MT3115 3236 00	WIPER	2
4a	MT3115 3196 02	GUIDE	2
5a	MT3115 3197 02	GUIDE	2

MT3115 2387 SK FLUSHING KIT 1838 MEX

ITEM	PART NUMBER	DESCRIPTION	QTY
1b	MT3115 2387 00	CUP SEAL	4
2b	MT0663 6143 01	O-RING	4
3b	MT0663 2126 01	O-RING	1

MT3128 0020 26 FEED FRONT

ITEM	PART NUMBER	DESCRIPTION	QTY
1	MT3128 3105 16	FRONT PLATE	1
2	MT3128 3097 90	WASHER	4
3	MT0663 2102 09	O-RING	4
4	MT3128 3097 91	SLEEVE	4
5	MT0663 6131 00	O-RING	4
6	MT0384 3546 00	DISC SPRING	16
7	MT3128 3097 93	INTERM PLATE	1
8	MT3128 3013 06	DRILL STEEL SUPPORT	1
9	MT3128 0618 PM	PROTECTION MAT	1
10	MT3128 0618 MM	MAT MOUNT	1
11	MT3128 0618 AP	ATTACHMENT PLATE	4
12	MT3128 0618 LW	MAT WASHER	3
13	MT3128 3047 81	CUTTING GUIDE	1
14	MT3128 0616 00	CUTTING RING	2
15	MT3128 0094 00	RUBBER CLOTH	1
16	MT3128 0682 00	SHIM	1
17	MT3128 0683 00	SHIM	2
18	MT3128 0090 00	COLLARING PART	1
19	MT3128 1311 75	HYDRAULIC CYLINDER	2
20	MT3128 0030 77	CYLINDER SEAL KIT (incl. spindle seals)	2
21	MT3128 0030 76	GUIDE SPINDLE	2
22	MT3128 0030 76SK	GUIDE SPINDLE SEAL KIT	2
23	MT3128 3141 35	COVER	2
24	MT3217 6246 47	PISTON ROD	2
25	MT3128 3013 89	SIMBA JAW HOLDER	2
26	MT0211 1963 02	SCREW M12x50 SHCS	16
27	MT0211 1963 44	SCREW M12x120 SHCS	6
28	MT0211 1963 42	SCREW M16x110 SHCS	6
29	MT0147 1501 03	SCREW M16x240	4
30	MT0211 1963 35	SCREW M20x90 SHCS	8
31	MT3128 3022 32	PIN	2
32	MT3128 0618 BP	PLUG	1
33	MT3128 0672 02	BSH ADJUSTING TOOL	1
34	MT3128 3039 2169	INTERM. PLATE - GUIDE 64mm (T45)	1
34.1	MT3128 3039 2181	INTERM. PLATE - GUIDE 76mm (T58)	1
34.2	MT3128 3039 21	INTERM. PLATE - GUIDE 87mm (T68)	1
35	MT3128 3023 51	CHECK 32mm SPEED ROD (R32)	2
35.1	MT3128 3023 92	CHECK 38mm SPEED ROD (ST38)	2
35.2	MT3128 3022 70	CHECK 45mm SPEED ROD (ST45)	2
35.3	MT3128 3023 92T	CHECK T38 TUBE JAW (T38)	2
35.4	MT3128 3022 17	CHECK 64mm TUBE JAW (T45)	2
35.5	MT3128 3014 00	CHECK T51 TUBE JAW (T51)	2
35.6	MT3128 3045 74	CHECK 76mm TUBE JAW (T58)	2
35.7	MT3128 3038 85	CHECK 87mm TUBE JAW (T68)	2
36	MT3128 0618 08	TUBE CUTTING GASKET 32-36mm (ST32)	2
36.1	MT3128 0618 07	TUBE CUTTING GASKET 38mm (ST38)	2
36.2	MT3128 0618 06	TUBE CUTTING GASKET 45mm (ST45)	2
36.3	MT3128 0618 00	TUBE CUTTING GASKET 64-76mm (T58)	2
36.4	MT3128 0618 01	TUBE CUTTING GASKET 87mm (T68)	2

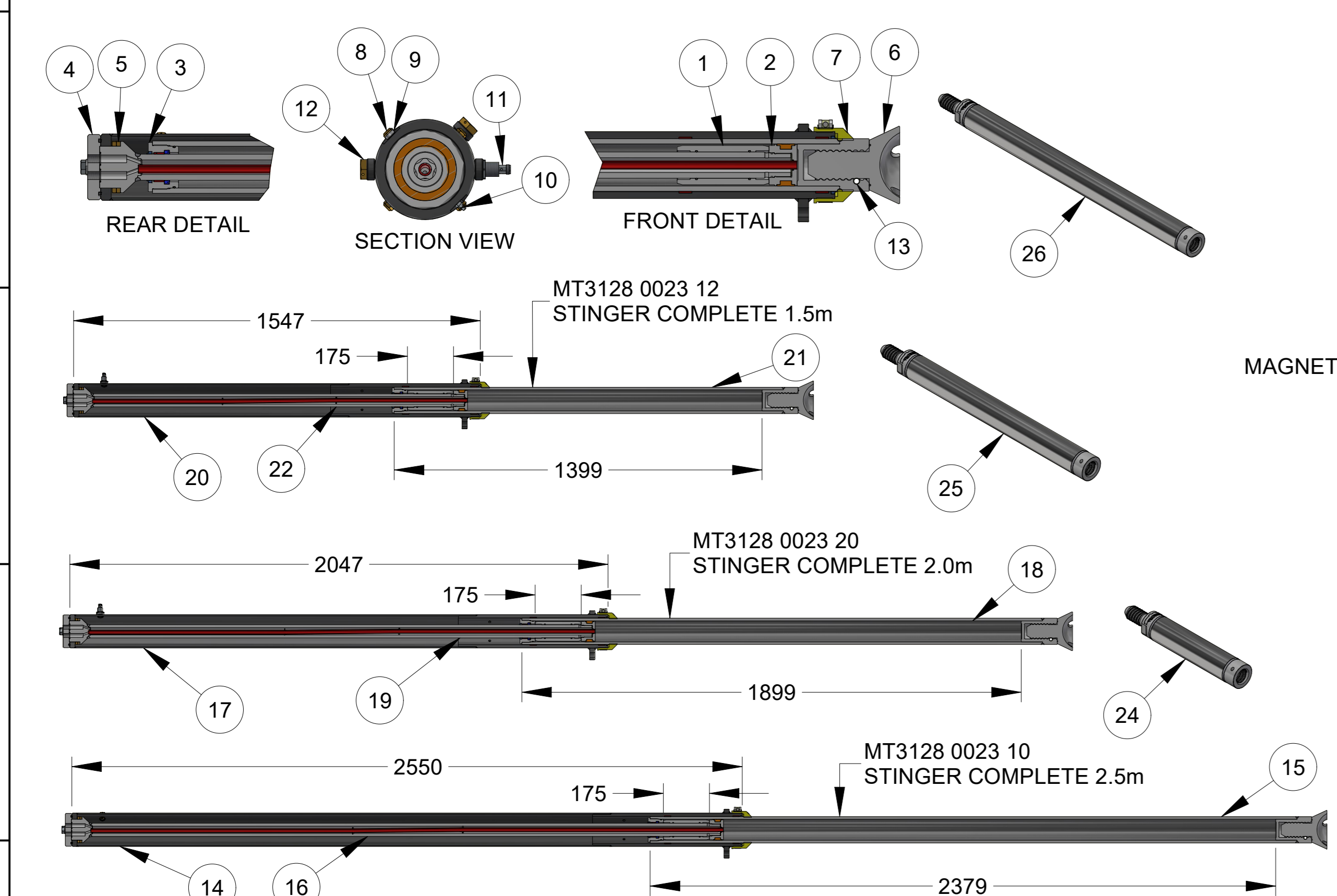

STINGERS - RHS27

ITEM	PART NUMBER	DESCRIPTION	QTY
1	MT9128 4285 175	SPACER	1
2	MT3128 2592 16	PISTON	1
3	MT9126 3960 00	COVER	1
4	MT9236 2017 61	BLOCK	1
5	MT9236 2017 62	WASHER	2
6	MT9236 2027 42	STINGER FOOT (MT only)	1
7	MT3128 2191 72S	SEAL + CLAMP	1
8	MT9236 2017 63	FILTER PLUG	4
9	MT3128 3005 37	PLUG	1
10	MT0544 2162 00	GREASE NIPPLE	1
11	MT9106 1856 01	INDUCTIVE SENSOR	1
12	MT9106 1856 01P	BREATHER PLUG (MT only)	2
13	MT9236 2027 421	PIN	1

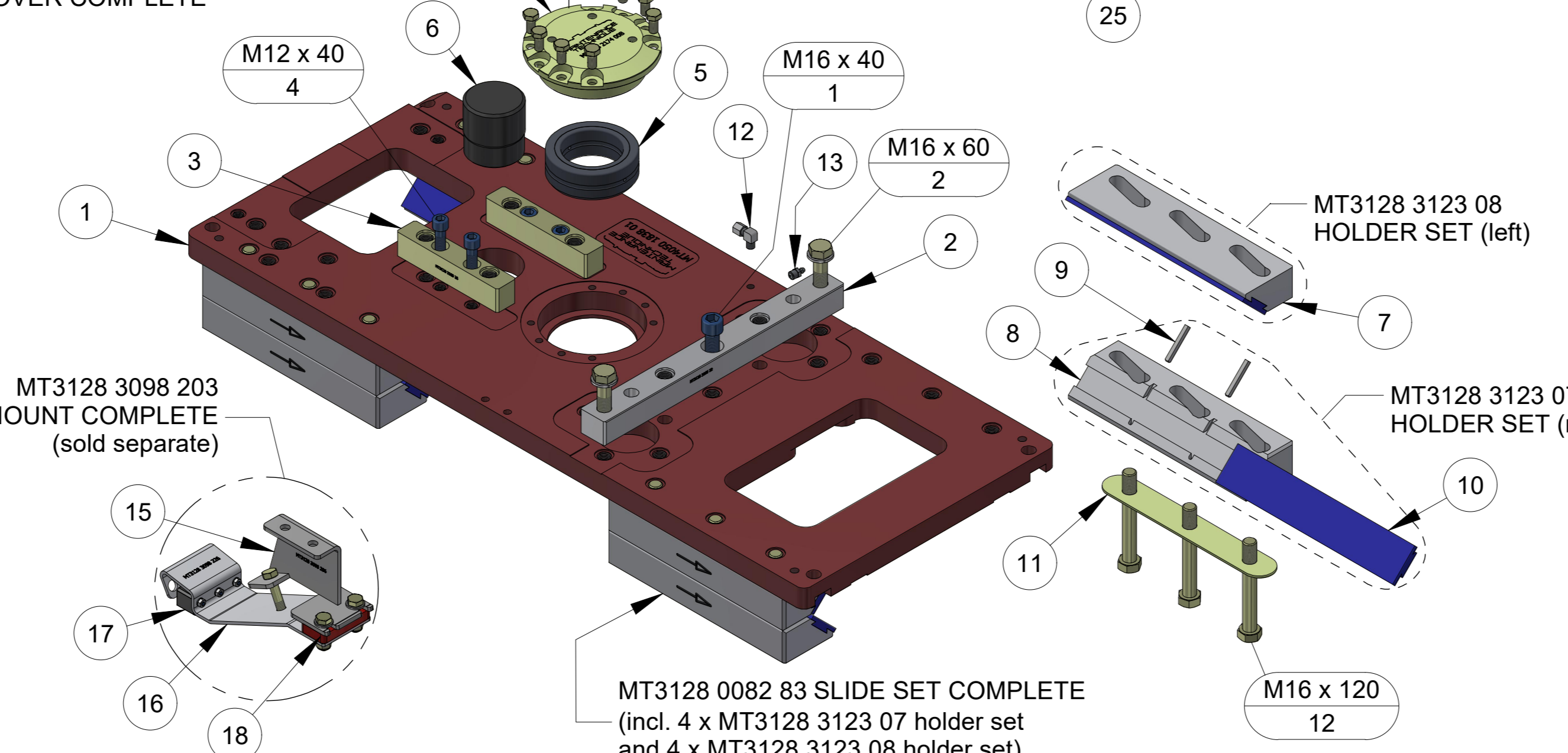

MT3128 0016 31 CRADLE COMPLETE - 1838

ITEM	PART NUMBER	DESCRIPTION	QTY
1	MT4050 1838 01	UNIVERSAL CRADLE	1
2	MT3128 3105 22	SPACER	1
3	MT3128 3105 20	SPACER	2
4	MT3128 2174 00B	BEARING COVER (MT only)	1
5	MT3128 0314 00	BEARING	1
6	MT3128 3098 07	DRIVER	1
7	MT3128 0083 00	SLIDE HOLDER LH	4
8	MT3128 0082 00	SLIDE HOLDER RH	4
9	MT3128 0646 00	SLIDE KEY	16
10	MT3128 3043 55	SLIDE - BLUE (Upholes - mid)	8
10.1	MT3128 3043 55H	SLIDE - WHITE (Downholes - hard)	0
11	MT0333 0500 03	WASHER PLATE	4
12	MT0580 2202 00	COUPLING 90°	1
13	MT0544 2162 00	GREASE NIPPLE	1
14	MT3128 0016 31BK	BOLT KIT	1

MT3128 3098 203 MAGNET MOUNT COMPLETE

ITEM	PART NUMBER	DESCRIPTION	QTY
15	MT3128 3098 206	MAGNET MOUNT	1
16	MT3128 3098 226	MAGNET HOLDING BRACKET	1
17	MT3128 3105 18	MAGNET (incl. bolts & nuts)	1
18	MT3176 5409 001	DAMPER KIT COMPLETE	1

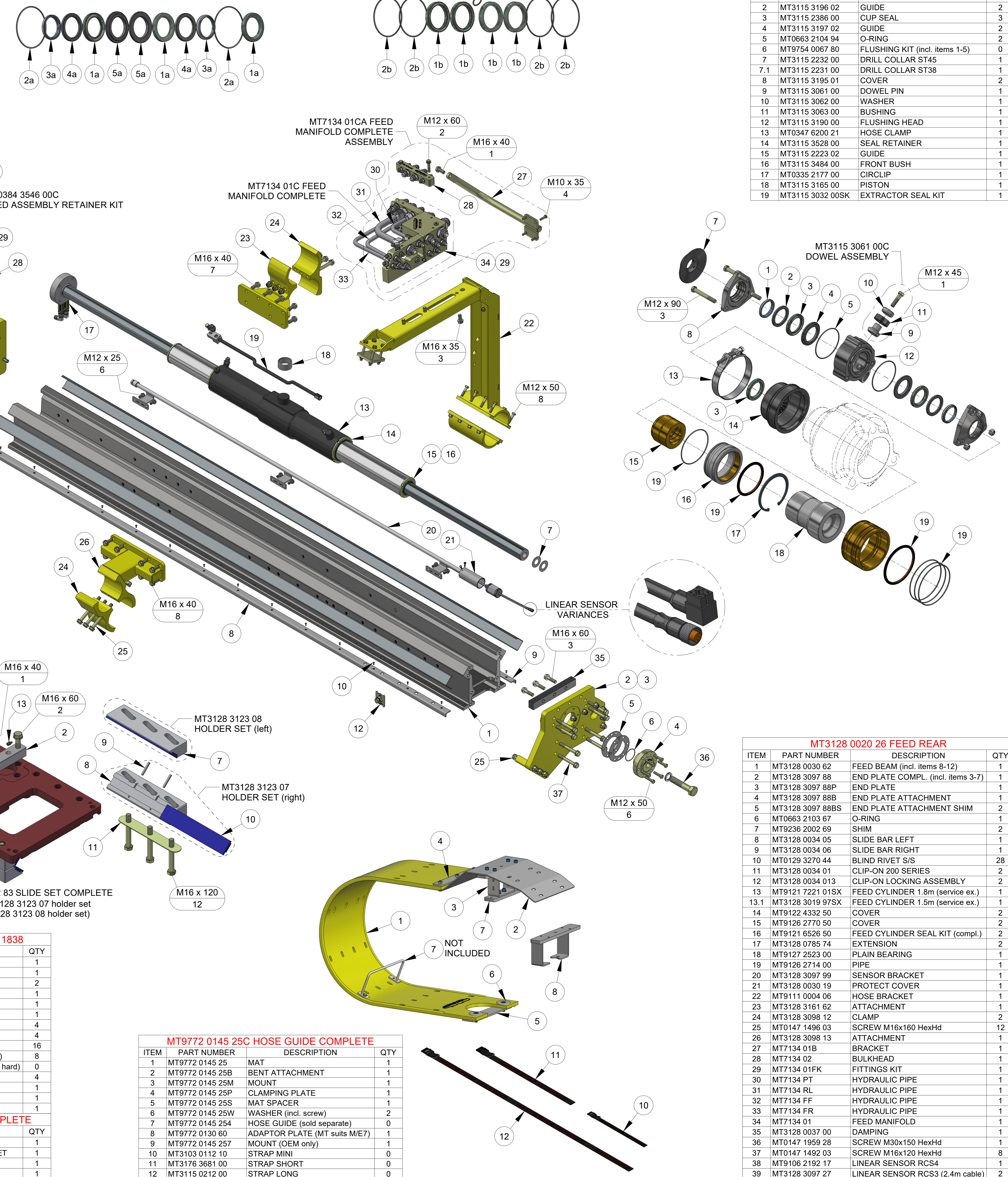

MT9772 0145 25C HOSE GUIDE COMPLETE

ITEM	PART NUMBER	DESCRIPTION	QTY
1	MT9772 0145 25	MAT	1
2	MT9772 0145 25B	BENT ATTACHMENT	1
3	MT9772 0145 25M	MOUNT	1
4	MT9772 0145 25P	CLAMPING PLATE	1
5	MT9772 0145 25S	MAT SPACER	1
6	MT9772 0145 25W	WASHER (incl. screw)	2
7	MT9772 0145 254	HOSE GUIDE (sold separately)	0
8	MT9772 0130 60	ADAPTOR PLATE (MT suits M/E7)	1
9	MT9772 0145 257	MOUNT (OEM only)	1
10	MT3103 0112 10	STRAP MINI	0
11	MT3176 3681 00	STRAP SHORT	0
12	MT3115 0212 00	STRAP LONG	0

MT3128 0020 26 FEED REAR

ITEM	PART NUMBER	DESCRIPTION	QTY
1	MT3128 0030 62	FEED BEAM (incl. items 8-12)	1
2	MT3128 3097 88	END PLATE COMPL. (incl. items 3-7)	1
3	MT3128 3097 88P	END PLATE	1
4	MT3128 3097 88B	END PLATE ATTACHMENT	1
5	MT3128 3097 88BS	END PLATE ATTACHMENT SHIM	2
6	MT0663 2103 67	O-RING	1
7	MT9236 2002 69	SHIM	2
8	MT3128 0034 05	SLIDE BAR LEFT	1
9	MT3128 0034 06	SLIDE BAR RIGHT	1
10	MT0129 3270 44	BLIND RIVET S/S	28
11	MT3128 0034 01	CLIP-ON 200 SERIES	2
12	MT3128 0034 013	CLIP-ON LOCKING ASSEMBLY	2
13	MT9121 7221 01SX	FEED CYLINDER 1.8m (service ex.)	1
13.1	MT3128 3019 97SX	FEED CYLINDER 1.5m (service ex.)	1
14	MT9122 4332 50	COVER	2
15	MT9126 2770 50	COVER	2
16	MT9121 6526 50	FEED CYLINDER SEAL KIT (compl.)	2
17	MT3128 0785 74	EXTENSION	2
18	MT9127 2523 00	PLAIN BEARING	1
19	MT9126 2714 00	PIPE	1
20	MT3128 3097 99	SENSOR BRACKET	1
21	MT3128 0030 19	PROTECT COVER	1
22	MT9111 0004 06	HOSE BRACKET	1
23	MT3128 3161 62	ATTACHMENT	1
24	MT3128 3098 12	CLAMP	1
25	MT0147 1496 03	SCREW M16x160 HexHd	12
26	MT3128 3098 13	ATTACHMENT	1
27	MT7134 01B	BRACKET	1
28	MT7134 02	BULKHEAD	1
29	MT7134 01FK	FITTINGS KIT	1
30	MT7134 PT	HYDRAULIC PIPE	1
31	MT7134 RL	HYDRAULIC PIPE	1
32	MT7134 FF	HYDRAULIC PIPE	1
33	MT7134 FR	HYDRAULIC PIPE	1
34	MT7134 01	FEED MANIFOLD	1
35	MT3128 0037 00	DAMPING	1
36	MT0147 1959 28	SCREW M30x150 HexHd	1
37	MT0147 1492 03	SCREW M16x120 HexHd	8
38	MT9106 2192 17	LINEAR SENSOR RCS4	1
39	MT3128 3097 27	LINEAR SENSOR RCS3 (2.4m cable)	2