

Auto Lube System Function and maintenance

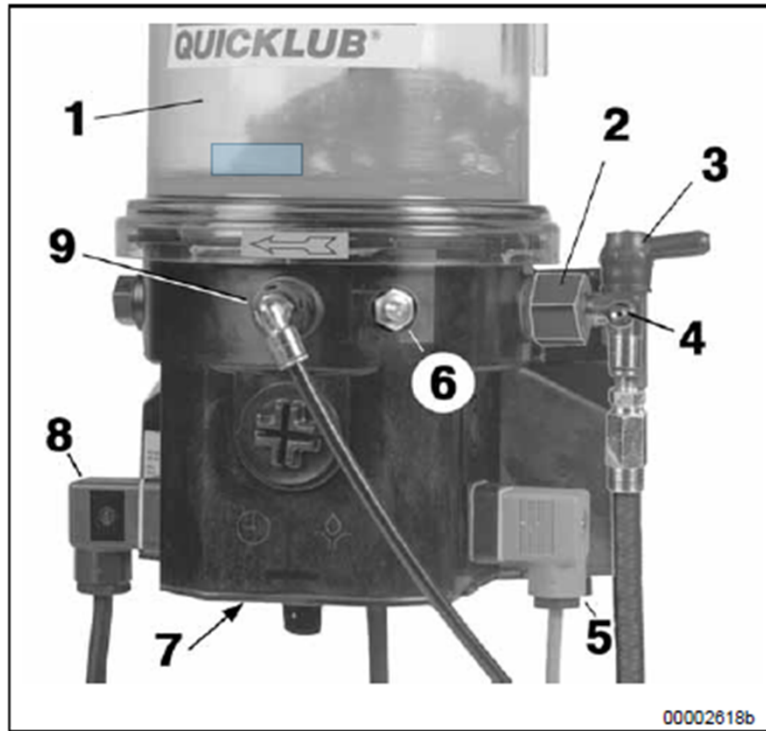

Fig. 2 Pump components

- | | |
|--|---|
| 1 - Reservoir | 5 - Plug 2A1
(V10-V13 : low level control) |
| 2 - Pump element | 6 - Filling nipple, reservoir |
| 3 - Safety valve | 7 - Printed circuit board |
| 4 - Filling nipple, system
Emergency lubrication possible | 8 - Plug 1A1 |
| | 9 - Return line connection |

2 Pump Element

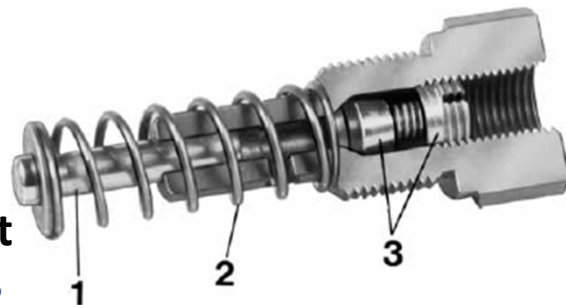

Fig. 4 P

- | | |
|-----------------|-------------------|
| 1 - Piston | 2 - Return spring |
| 3 - Check valve | |

PUMP

- The pump is powered by a 24v motor, controlled by a timer system detailed on the next page.
- Power is supplied (normally via a pressure switch) to Din plug 8.
- The pump can have up to 3 pumping elements fitted, supplied separately.
- If fitted, these elements are operated once per revolution by an eccentric cam in the pump.
- A relief is fitted to each pump outlet to ensure that if the outlet is blocked the pump motor will not stall.
- Discharge from the relief indicates that lube circuit is not cycling.

Tighten to
20nm only.

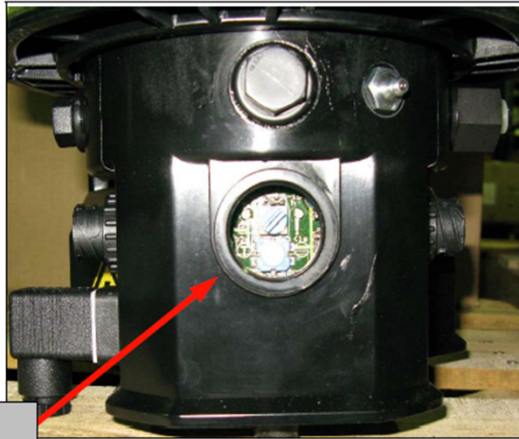

Remove the plug on the front to gain access to the PC board.

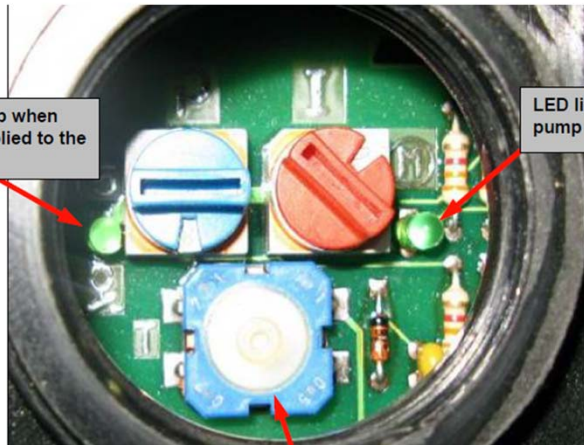

LED lights up when power is applied to the PC board.

LED lights up when pump is in operation

Quicklube Timer

- Remove the plastic cap over the timer unit
- Left LED indicates Power supply to the Pump
- Right LED indicates Pump is in operation
- Blue dial sets the OFF time of the pump
- Red Dial Sets the RUN time of the pump as per table below
- Blue button below activates a pumping sequence when held down for 2 seconds.
- Note - When the Dial is set to 0 a failure report at the LED will take place. See trouble shooting page.

Blue PAUSE timer dial

switch position	1	2	3	4	5	6	7	8	9	A	B	C	D	E	F
minutes	4	8	12	16	20	24	28	32	36	40	44	48	52	56	60
hours	1	2	3	4	5	6	7	8	9	10	11	12	13	14	15

Red RUN timer dial

switch position	1	2	3	4	5	6	7	8	9	A	B	C	D	E	F
seconds	8	16	24	32	40	48	56	64	72	80	88	96	104	112	120
minutes	2	4	6	8	10	12	14	16	18	20	22	24	26	28	30

Divider valve

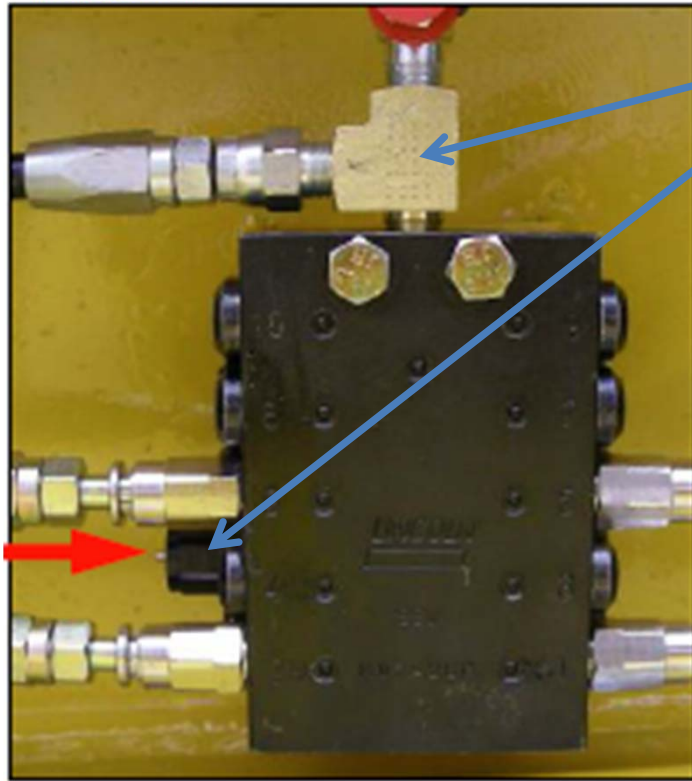

- Grease is supplied to the block through the centre inlet.
- An optional indicator button can be fitted to show each time the divider completes a cycle.
- Figure 3 shows the check valve with brass seal fitted to each block outlet, which blocks the bypass port.
- **If the brass seal is not fitted the grease will be diverted to the outlet next to it though a bypass port.**
- The divider must fully discharge to each outlet before moving to the next outlet, **never plug or block a grease hose.** A blanking cap (4) can be fitted at the divider.
- **Port 1 and 2 must always be used, if blanked they do not have a bypass port and the divider will not operate.**

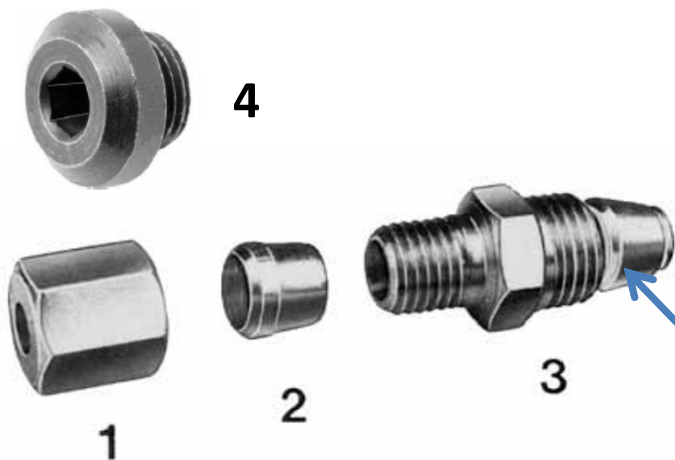

bypass ports
blocked by
the brass
Check seal.

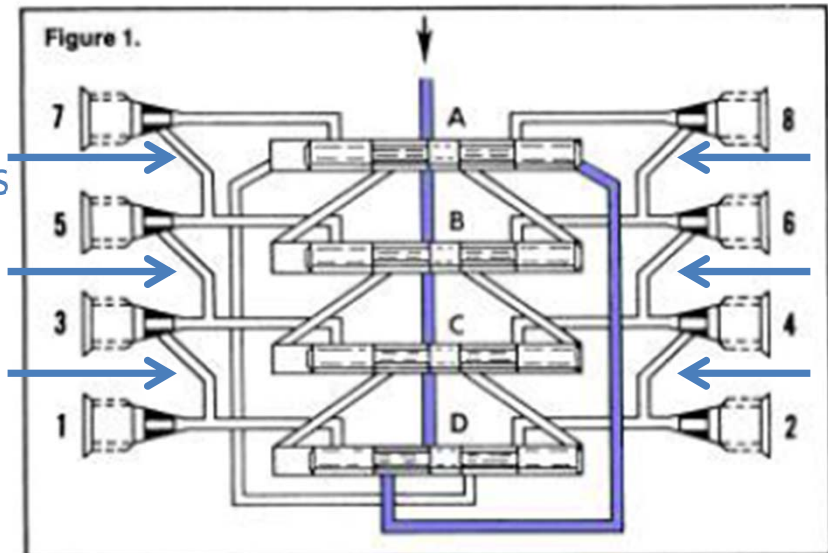

Troubleshooting

Fault: The pump motor does not run

Cause:

- Power supply interrupted
- Electric motor defective
- p.c.b. defective

Remedy ...

by service people

- ☞ Check the power supply and fuses.
- ☞ If necessary rectify the fault and/or replace the fuses.
- ☞ Check the line leading from the fuses to the pump plug.
- ☞ Check the power supply to the motor. If necessary, replace the motor.
- ☞ Check the function of the p.c.b. (see paragraph "Operational Test / To Trigger an additional Operating Cycle", page 21).
- ☞ If necessary replace the p.c.b..

Fault: The pump does not deliver the lubricant

Cause :

- Reservoir empty

Remedy ...

by user, owner

- ☞ Fill up the reservoir with clean grease or oil. Allow pump to run (trigger an additional lube cycle, see page 21) until the lubricant issues from all the lubrication points.



6001a02

NOTE

If a lubricant low-level is available, the low level is indicated by the flashing light of the signal lamp in the case of pumps without printed circuit board. The flashing frequency depends on the speed of the motor.

NOTE

Depending on the ambient temperature and/or sort of lubricant it may take 10 minutes of operation before the pump elements reach their full lubricant output.

- Air bubbles in the lubricant

- ☞ Trigger an additional operating cycle (see page 21). Loosen the outlet fitting or the main line at the pressure relief valve. The lubricant must issue without air bubbles.



6001a02

NOTE

When push-in type fittings are used, the high-pressure hose which is under pressure cannot be easily disconnected from the pressure relief valve. For this purpose, loosen the pressure relief valve. For this purpose, filling nipple on the pressure relief valve in order to relieve the high-pressure hose.

- Unsuitable lubricant has been used

- ☞ Renew the lubricant. See the Lubricant List (see page 36 ff).

- Suction hole of the pump element clogged

- ☞ Remove the pump element. Check the suction hole for foreign particles. If there are any, remove them.

- Pump piston worn

- ☞ Replace the pump element.

- Check valve in the pump element defective or clogged.

- ☞ Replace the pump element.

Fault indication

Rotary switch set to "0"

- When one of the rotary switches pos. 2 and/or pos. 4, fig. 29 is set to "0", a fault is shown on the right LED pos. 3.
- The fault is indicated by 4 flashes of the LED.
- The pump motor also runs according the flash frequency. If the warning is ignored the controller automatically adopts the **factory-set** values for the lubricating or pause time.

Pushbutton 5 fig. 29 continuously actuated (short circuit)

- If a short circuit occurs at the pushbutton or is present at the external illuminated pushbutton, (or at the connecting parts) a fault is shown on the right LED pos. 3.
- The fault is indicated by 3 flashes of the LED when the voltage supply is switched on.
- The motor of the pump also runs according to the flash frequency.

Electrical Data

Input

Input voltage	24 VDC ¹⁾
.....	110-240 VAC ±10% ; 50/60 Hz ±5% ²⁾
Input current	200 mA at 230 VAC
Starting current impact	< 18 A
Fuse	T 1,25 A/250 V intern
¹⁾ without power supply p.c.b.	
²⁾ with power supply p.c.b.	

Output

Output voltage, internal	24 VDC ±1%
--------------------------------	------------

Protection and monitoring

Current limiting	resistant to sustained short circuit
Overload-proof	yes
Idling-proof	yes
Mains buffering time	> 15 ms at 230 VAC

Safety VDE 085 / 11.93 / EN 60950 / IEC 950, EN 60204

Output	safety extra-low voltage (SELV)
Class of protection	class 1
Discharge current	< 0,25 mA (47-63 Hz and U _{ON} max.)



6001a02

NOTE

The control p.c.b. needs VDC supply voltage.

Operating Mode

The pump is designed for intermittent operation, not for permanent operation.

Max. lubricating time	30 minutes
Min. pause time	4 minutes

Internal protection

If the internal fuse has to be replaced use only the original Lincoln spare part for repair on the pump.









Motor

DC gear motor (interference-suppressed)

Noise emission	< 70 dB(A)
- Operating voltage.....	24VDC
- Max. current input	
24V	3 A
Speed	approx. 17 rpm

Critical Spares

The **MT3128 2538 189** Auto Grease kit is a 'critical spares' stock of components needed for maintenance and repair of the Lincoln auto lubrication system. The storage box contains.

Component	Description	MT part number	Qty
	Straight Coupling	MT0580 0002 00	10
	Coupling 90 deg	MT0580 2202 00	10
	1/8 grease nipple	MT0544 2162 00	10
	Gasket, for blanking plug	MT0653 1041 00	6
	Safety Valve, Pump Outlet	MT3128 2538 02	1
	Hose joiner	MT3128 2538 08J	10
	Threaded sleeve	MT3128 2538 08	20
	Hose Adapter Straight	MT3128 2538 09	10
	High Power Pipe, per/meter	MT3128 2538 10	10
	Adapter T – To grease block	MT3128 2538 12	2
	Grease Distributor Block 6 port , indicator	MT3128 2538 17	1
	Grease Distributor Block 12 port	MT3128 2538 18	1
	Hose Adapter, 90 deg	MT3128 2538 90	10
	Check valve, for grease block	MT3128 2539 95	6
	Plug, for grease block	MT3128 3005 37	6
	Storage Box	MT9106 1900 012	1

